



Energy Smart

Recovery Unit

TECHNICAL LEAFLET

Energy Smart

Recovery Unit



The Sabiana Energy Smart units are high efficiency ventilation units with heat recovery and are designed for residential ambiances.

The units replace the exhaust air of indoor environments with filtered air coming from the outside thanks to a special high efficiency ePM₁ 55% - F7 class filter.

The hexagonal counterflow recovery unit prevents any winter heat drops due to the introduction of fresh air, thereby recovering up to 92.5% of the extracted heat and conveying it to the clean air introduced in the occupied environment. Depending on requirements and climatic conditions, one can choose the heat exchanger that acts only on temperature (sensible) or also on humidity (enthalpic).

The latter is able to transmit both humidity and heat, taken from the extracted air, to the fresh intake air, thus preventing the indoor air from becoming too dry.

The enthalpy heat exchanger is available as an option for all Energy Smart units except the SHP-150 model.

Each unit is also equipped with an average efficiency filter (ePM₁₀ 50% - M5) installed on the inlet of the extraction section to prevent any dust from getting into the equipment.

All Energy Smart units comply with the 2018 efficiency limits imposed by Regulation 1253/14.

The Pro versions are equipped with an automatic centralised air flow control system operated by an integrated humidity sensor located in the extracted air duct. If the humidity of the indoor environment exceeds the reference parameters, to prevent the proliferation of mould and pathogenic bacteria, the fresh air flow is increased with the aim of restoring a healthy humidity level. The control also prevents from dropping below excessively low humidity levels, thus preventing excessively dry conditions inside the environments and, as a result, any health hazards. The units

are NOT able, by themselves, to lower the level of internal humidity to a value below that of the outdoor. All the units can be controlled by means of a **supervisory system** in accordance with the following protocols:

- **Modbus**, with direct access to the dedicated RS 485 web gateway
- **Konnex**, with KNX interface board (optional)

As well as the type of installation, the range can also be classified according to the type of control:

- **Pro unit** with automatic centralised control via humidity probe:
 - ENY-SP (vertical)
 - ENY-SHP (horizontal/vertical)
- **Standard unit** with time programming control:
 - ENY-S (vertical)

ENY-SP and ENY-S units are designed for vertical wall installation or, with the addition of feet, floor installation. The ENY-SP-225 unit, very compact, is designed for the wall installation inside a standard ceiling unit for the kitchen or the wardrobe. Instead, ENY-SHP units are ideal for both horizontal ceiling installation and vertical wall installation. The width of the ENY-SHP and ENY-S units is such as to ensure easy insertion into modular kitchen components, since the width is less than 600 mm.



Energy Smart SP-225



Energy Smart SHP 150

Energy Smart

ENY-SP and ENY-S vertical Energy Smart units

The Pro Versions are available in Class A + while the Standard versions are in Class A. Both are equipped with high efficiency backward-curved blades and EC motors, driven by the integrated inverter control board for variable speed control.

All units have a remote control user interface (T-EP control), integrated in the inspection cover of ENY-SP and ENY-S units; for the latter, it is also possible to disconnect the interface from the inspection cover and place it on the wall using a special cable.

The Pro versions are Passivhaus certified and are equipped with a centralized automatic flow rate control system, that works not only in accordance with a built-in humidity sensor, but also in response to CO₂ measurements. In this case, it is recommended to connect a 0-10V CO₂ sensor to the main control board, available on the market.



CHARACTERISTICS

The units with automatic control via humidity or CO₂ sensor can enable the "AUTO" mode. In this mode, the fan speed is controlled by an automatic control cycle relating to internal instantaneous humidity and CO₂ variations. In variable-flow automatic control mode, the user can still intervene at any time by changing the fan speed manually as required. The automatic mode will be restored at the next significant variation of ambient humidity or concentration of CO₂.

In the event that the user does not require automatic control but just simply time programming or even manual control, standard units are ideal.

There is a choice of 8 weekly programs for these units: 4 preset programs and 4 free programs that can be modified as required. The operation can be selected in various intervals of the day, at one of the **4 standard speeds**, or at the hyperventilation speed "**Party**". At any time, the user may force the programming manually, which will resume at the beginning of the next time interval.

In manual mode, in addition to the nominal speed, **there are 3 default speeds equal to 70%, 45%, and 25% of the project flow rate**. The timed intensive ventilation modes can be activated via the user interface ("Party" mode) or via a remote switch located in a particular room ("Booster" mode).



All the units are equipped with an automatic bypass system that totally disables use of the recovery unit to permit 100% **free-cooling** (or **free-heating**). The system is controlled by logic subject to the feedback of the embedded temperature sensors.

Also, the units have the following integrated control logic:

- The mass supply flow defined by the user is kept constant in all outdoor climatic conditions.
- The extraction flow is kept at a constant balancing percentage compared to the air supply flow, in order to preserve the desired overpressure or negative pressure for all operating conditions.

When installing the units in homes located in regions with particularly harsh climatic conditions, we recommend installing the units with integrated filament electric heaters (E versions), where the thermal power is continuously modulated to maintain exhaust air at the desired temperature, preventing freezing. For all models, it is possible to use an external antifreeze coil, with continuous modulation available as accessory on price list.

To prevent excessive efficiency drops due to filter clogging, it is recommended to replace the filters at the end of the recommended period (usually every 6 months). The increase in filter dirt in fact leads to increased fan rotation resistance, causing a significant drop in flow rates. With regard to ENY S units, the automatic constant flow control system (standard for the ENY-SP units), which prevents any drops in flow rates due to filter clogging, is available as an accessory. In this case, filter clogging may result in a significant increase in power consumption of the fans.

If the flows need to be inverted, all units are reversible during installation (except for versions with electric heater).

For each model, a complete set of Accessories is also available to meet any installation need.

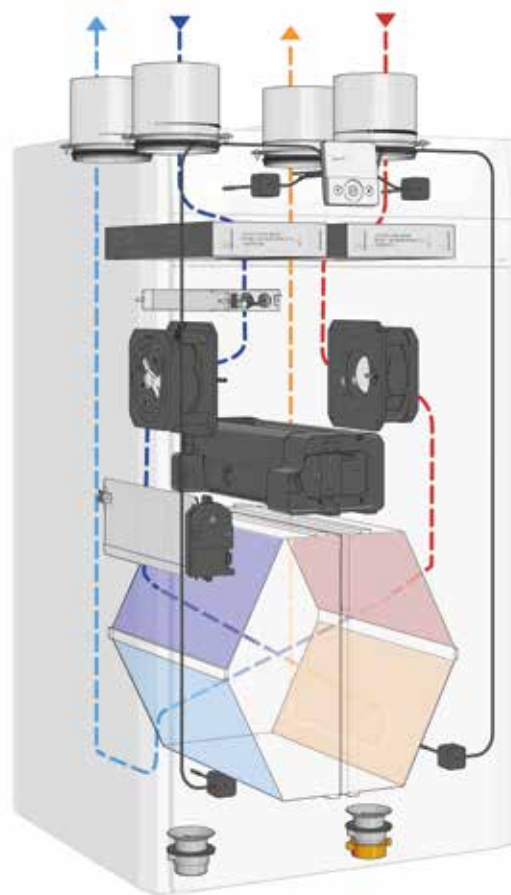

ENY-SHP horizontal and vertical Energy Smart units

The Energy Smart horizontal units are available in three sizes ENY-SHP-150 ENY-SHP-170 and ENY-SHP-270 both in the Pro version only, that means they are equipped with an automatic centralized air flow control system operated by an integrated humidity sensor located in the extract air duct. They are ideal for both horizontal ceiling installation and vertical wall installation; sizes 150 and 170 are Passivhaus certified.

The **SHP-150** size is distinguished by its extremely compact dimensions that make it easy to install in a false ceiling. The unit is equipped with a fitted control panel, that lets the calibration and activation of the unit.

The Energy Smart ENY-SHP-150 unit can be connected to the T-EP remote control panel accessory to activate the following additional functions:

- Party Mode.
- Holiday Mode.
- Free cooling Mode: a single supply air flow to activate manually.
- There is a choice of 8 weekly programs for these units: 4 preset programs and 4 free programs that can be modified as required.
- Fan speed regulation by means of the T-EP touch pad by selecting one of the 3 default speeds equal to 70%, 45%, and 25% of the project flow rate.

The **SHP-170** size, like the Energy Smart Pro vertical units, is equipped with a motorized bypass system with a double damper, that totally disables use of the heat recovery unit to permit 100% free-cooling (or free-heating) automatically and it is equipped as standard with a T-EP control panel.

The ENY-SHP-170 is also available with integrated filament electric heaters (E version), in which the thermal power is continuously modulated to keep the exhaust air at the desired temperature, thereby preventing any freezing.

The **SHP-270** is distinguished by the perfect blend between compact dimensions and high air flows. The unit is equipped as standard with a T-EP control panel.

The ENY-SHP-270 is equipped with a motorized bypass system with a double damper, that totally disables the heat exchange between the air flows to permit 100% free-cooling (or free-heating) automatically.

The ENY-SHP-270 is also available with integrated filament electric heaters (E version), in which the thermal power is continuously modulated to keep the exhaust air temperature always within the safety limits, thereby preventing any freezing.

The ENY-SHP-270 is also equipped as standard with two humidity sensors and an advanced flow control system which allows an optimal control of the environment hygrometric conditions.

If in need of heating or cooling the air supplied to the ambient, different features are available for the supply and regulation of the post-treatment systems.

The valves of the post-treatment sections can be controlled by the electronic board fitted on the Energy Smart SHP-270 unit.

Vertical version with T-EP built-in/wall control

Pro Version

Version	Model	Max flow at 100 Pa (m ³ /h)	Energy class	Width (mm)	Humidity Sensor	Automatic air flow control	Code
Pro	ENY-SP-180	180	A+	600	✓	✓	021B001
	ENY-SP-225	225	A	547	✓	✓	021V001
	ENY-SP-280	280	A+	600	✓	✓	021B002
	ENY-SP-370	370	A+	660	✓	✓	021B003
	ENY-SP-460	460	A	660	✓	✓	021B004
	ENY-SP-600	600	A	660	✓	✓	021B005
Pro with LH electric heater	ENY-SPEL-180	180	A+	600	✓	✓	021B011
	ENY-SPEL-225	225	A	547	✓	✓	021V011
	ENY-SPEL-280	280	A+	600	✓	✓	021B012
	ENY-SPEL-370	370	A+	660	✓	✓	021B013
	ENY-SPEL-460	460	A	660	✓	✓	021B014
	ENY-SPEL-600	600	A	660	✓	✓	021B015
Pro with RH electric heater	ENY-SPER-180	180	A+	600	✓	✓	021B021
	ENY-SPER-225	225	A	547	✓	✓	021V021
	ENY-SPER-280	280	A+	600	✓	✓	021B022
	ENY-SPER-370	370	A+	660	✓	✓	021B023
	ENY-SPER-460	460	A	660	✓	✓	021B024
	ENY-SPER-600	600	A	660	✓	✓	021B025

Standard Version

Version	Model	Max flow at 100 Pa (m ³ /h)	Energy class	Width (mm)	Humidity Sensor	Automatic air flow control	Code
Standard	ENY-S-170	170	A	550	(*)	(**)	021A001
	ENY-S-270	270	A	550	(*)	(**)	021A002
	ENY-S-360	360	A	550	(*)	(**)	021A003
	ENY-S-460	460	A	660	(*)	(**)	021A004
	ENY-S-600	600	A	660	(*)	(**)	021A005
Standard with LH electric heater	ENY-SEL-170	170	A	550	(*)	(**)	021A011
	ENY-SEL-270	270	A	550	(*)	(**)	021A012
	ENY-SEL-360	360	A	550	(*)	(**)	021A013
	ENY-SEL-460	460	A	660	(*)	(**)	021A014
	ENY-SEL-600	600	A	660	(*)	(**)	021A015
Standard with RH electric heater	ENY-SER-170	170	A	550	(*)	(**)	021A021
	ENY-SER-270	270	A	550	(*)	(**)	021A022
	ENY-SER-360	360	A	550	(*)	(**)	021A023
	ENY-SER-460	460	A	660	(*)	(**)	021A024
	ENY-SER-600	600	A	660	(*)	(**)	021A025

(*) Humidity Sensor available as accessory
 (***) T-EP wall control available as accessory

(**) Pressure transducer for the automatic control of air flow rates, available as accessory

Horizontal and vertical version

Version	Model	Max flow at 100 Pa (m ³ /h)	Energy class	Height (mm)	Humidity Sensor	Autom. airflow control	T-EP	Code
Pro	ENY-SHP-150	150	A	191	✓	✓	(***)	021C002
	ENY-SHP-170	170	A+	330	✓	ND	✓	021C001
	ENY-SHPL-270 ⁽¹⁾	270	A	278	✓ ⁽³⁾	✓	✓	021C003
	ENY-SHPL-270 ⁽²⁾	270	A	278	✓ ⁽³⁾	✓	✓	021C003D
Pro left range with electric heater	ENY-SHPEL-170	170	A+	330	✓	ND	✓	021C011
	ENY-SHPEL-270	270	A	278	✓ ⁽³⁾	✓	✓	021C013
Pro right range with electric heater	ENY-SHPER-170	170	A+	330	✓	ND	✓	021C021
	ENY-SHPER-270	270	A	278	✓ ⁽³⁾	✓	✓	021C023

(1) left configuration (2) right configuration (3) double sensor

Energy Smart units are suitable for operation in balanced or slightly unbalanced flow and return conditions. They ensure residential air exchange, recovering the heat from the extracted air and conveying it to the clean air. The chart below shows the recommended operating ranges in terms of volumetric supply air flow rate at standard conditions and available external static pressure.

Pro ENY-SP vertical version

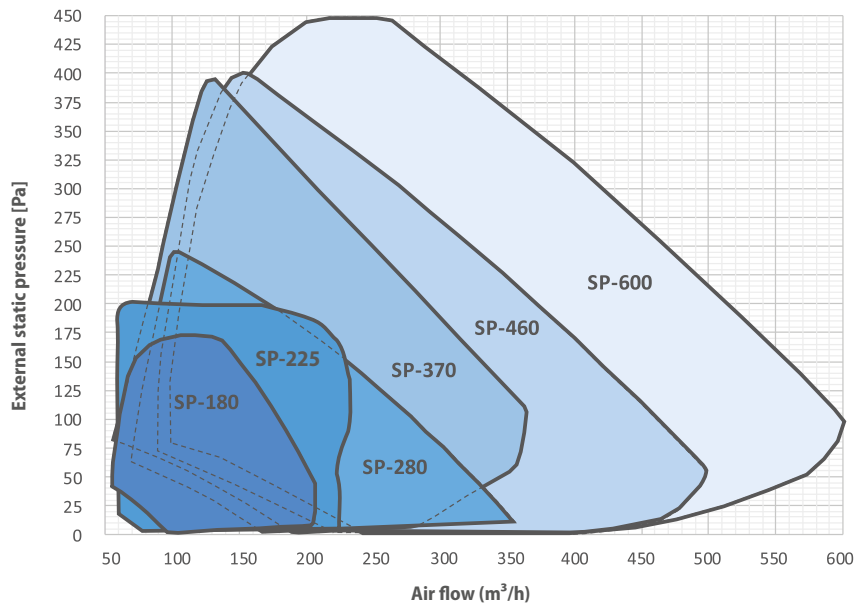

	Model	ENY-SP-180	ENY-SP-225	ENY-SP-280	ENY-SP-370	ENY-SP-460	ENY-SP-600
Q_{max}	m³/h	180	225	280	370	460	600
Q_{rif}	m³/h	130	158	200	260	320	420
P_{el}	W	23	47,4	35	47	76	105
η^t_{rvu}	%	91,5%	89,0%	91,4%	92,5%	88,6%	88,0%
SPI	W/m³/h	0,174	0,3	0,174	0,179	0,237	0,247
CTRL	-	0,85	0,85	0,85	0,85	0,85	0,85
SEC	kWh/m²a	-42,32	-38,6	-42,29	-42,47	-40,10	-39,71
Energy class	-	A+	A	A+	A+	A	A
Filter efficiency	-	ePM ₁ 55% - F7 ePM ₁₀ 50% - M5					
L_{WA}	dB(a)	38,9	43	43,1	46,3	47,9	52,4
LK_i	%	1,2%	1,7%	0,7%	0,5%	0,3%	0,60%
LK_E	%	1,7%	1,8%	1,0%	0,8%	0,7%	1,84%
HEP	W	500	800	900	1250	1600	2000

LEGEND (all terms must be considered in compliance with Standard EU 1253/2014)

Q_{max} = Maximum flow rate, at max motor speed and external static pressure of 100 Pa

Q_{rif} = Reference flow rate - 70% of Q_{max}

P_{el} = Power supply at Q_{rif} and external static pressure of 50 Pa

η^t_{rvu} = Thermal efficiency at Q_{rif}

SPI = Specific power input

CTRL = Control factor - Centralised automatic control

SEC = Specific energy consumption

L_{WA} = Sound power level emitted by structure

LK_i = Internal leakage at 100 Pa compared to Q_{rif}

LK_E = External leakage at 250 Pa compared to Q_{rif}

HEP = Pre-heater power (only mod. SPEL and SPER)

ENY-S vertical standard version

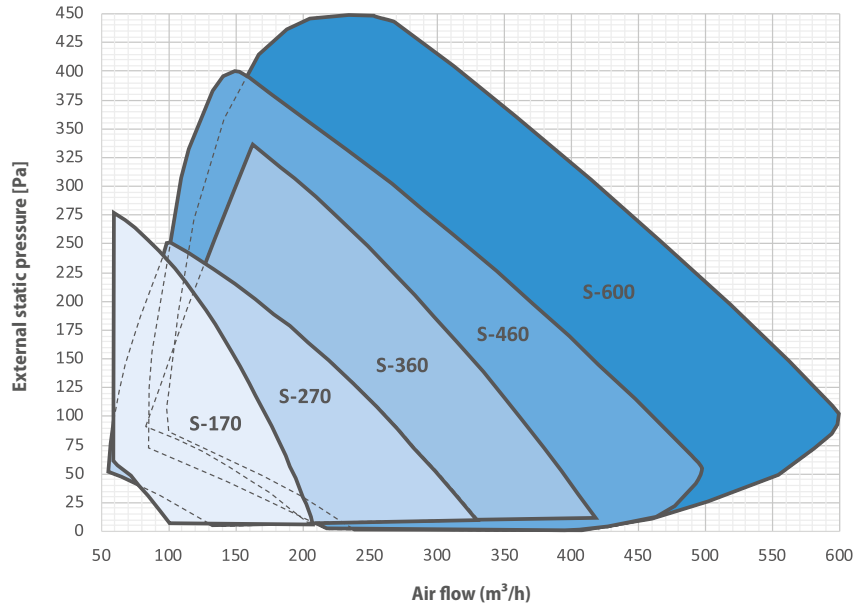

Model		ENY-S-170	ENY-S-270	ENY-S-360	ENY-S-460	ENY-S-600
Q _{max}	m ³ /h	170	270	360	460	600
Q _{rif}	m ³ /h	120	190	250	320	420
P _{el}	W	22	35	53	76	104
η ^t _{rvu}	%	87,0%	86,5%	90,1%	88,6%	88,0%
SPI	W/m ³ /h	0,183	0,184	0,209	0,237	0,247
CTRL	-	0,95	0,95	0,95	0,95	0,95
SEC	kWh/m ² a	-39,4	-39,3	-39,6	-38,4	-37,9
Energy class	-	A	A	A	A	A
Filter efficiency	-	ePM ₁ 55% - F7 ePM ₁₀ 50% - M5	ePM ₁ 55% - F7 ePM ₁₀ 50% - M5	ePM ₁ 55% - F7 ePM ₁₀ 50% - M5	ePM ₁ 55% - F7 ePM ₁₀ 50% - M5	ePM ₁ 55% - F7 ePM ₁₀ 50% - M5
L _{WA}	dB(a)	40,6	46,6	49,0	47,9	52,4
LK _I	%	0,4%	0,4%	0,7%	0,3%	0,6%
LK _E	%	1,8%	1,4%	2,7%	0,7%	1,84%
HEP	W	500	900	1250	1600	2000

LEGEND (all terms must be considered in compliance with Standard EU 1253/2014)

- Q_{max}** = Maximum flow rate, at max motor speed and external static pressure of 100 Pa
- Q_{rif}** = Reference flow rate - 70% of Q_{max}
- P_{el}** = Power supply at Q_{rif} and external static pressure of 50 Pa
- η^t_{rvu}** = Thermal efficiency at Q_{rif}
- SPI** = Specific power input
- CTRL** = Control factor - Centralised automatic control

- SEC** = Specific energy consumption
- L_{WA}** = Sound power level emitted by structure
- LK_I** = Internal leakage at 100 Pa compared to Q_{rif}
- LK_E** = External leakage at 250 Pa compared to Q_{rif}
- HEP** = Pre-heater power (only mod. SEL and SER)

Pro ENY-SHP version

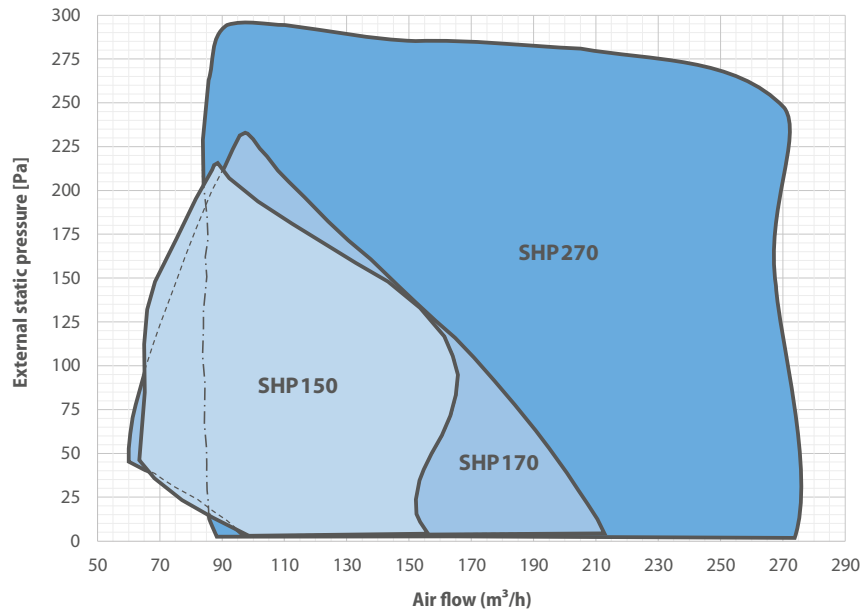

Model		ENY-SHP-150	ENY-SHP-170	ENY-SHP-270
Q_{max}	m ³ /h	150	170	270
Q_{rif}	m ³ /h	105	120	190
P_{el}	W	56	23	47,8
η^t_{rvu}	%	87%	92,1%	84,4%
SPI	W/m ³ /h	0,227	0,193	0,24
CTRL	-	0,85	0,85	0,85
SEC	kWh/m ² a	-39,90	-42,05	-38,9
Energy class	-	A	A+	A
Filter efficiency	-	ePM ₁ 55% - F7 ePM ₁₀ 50% - M5	ePM ₁ 55% - F7 ePM ₁₀ 50% - M5	ePM ₁ 55% - F7 ePM ₁₀ 50% - M5
L_{WA}	dB(a)	38,0	44,9	41,3
LK_i	%	1,8	0,5%	0,4
LK_E	%	0,8	2,3%	1,1
HEP	W	-	600	900

LEGEND (all terms must be considered in compliance with Standard EU 1253/2014)

Q_{max} = Maximum flow rate, at max motor speed and external static pressure of 100 Pa

Q_{rif} = Reference flow rate - 70% of Q_{max}

P_{el} = Power supply at Q_{rif} and external static pressure of 50 Pa

η^t_{rvu} = Thermal efficiency at Q_{rif}

SPI = Specific power input

CTRL = Control factor - Centralised automatic control

SEC = Specific energy consumption

L_{WA} = Sound power level emitted by structure

LK_i = Internal leakage at 100 Pa compared to Q_{rif}

LK_E = External leakage at 250 Pa compared to Q_{rif}

HEP = Pre-heater power (only mod. SHPEL and SHPER)

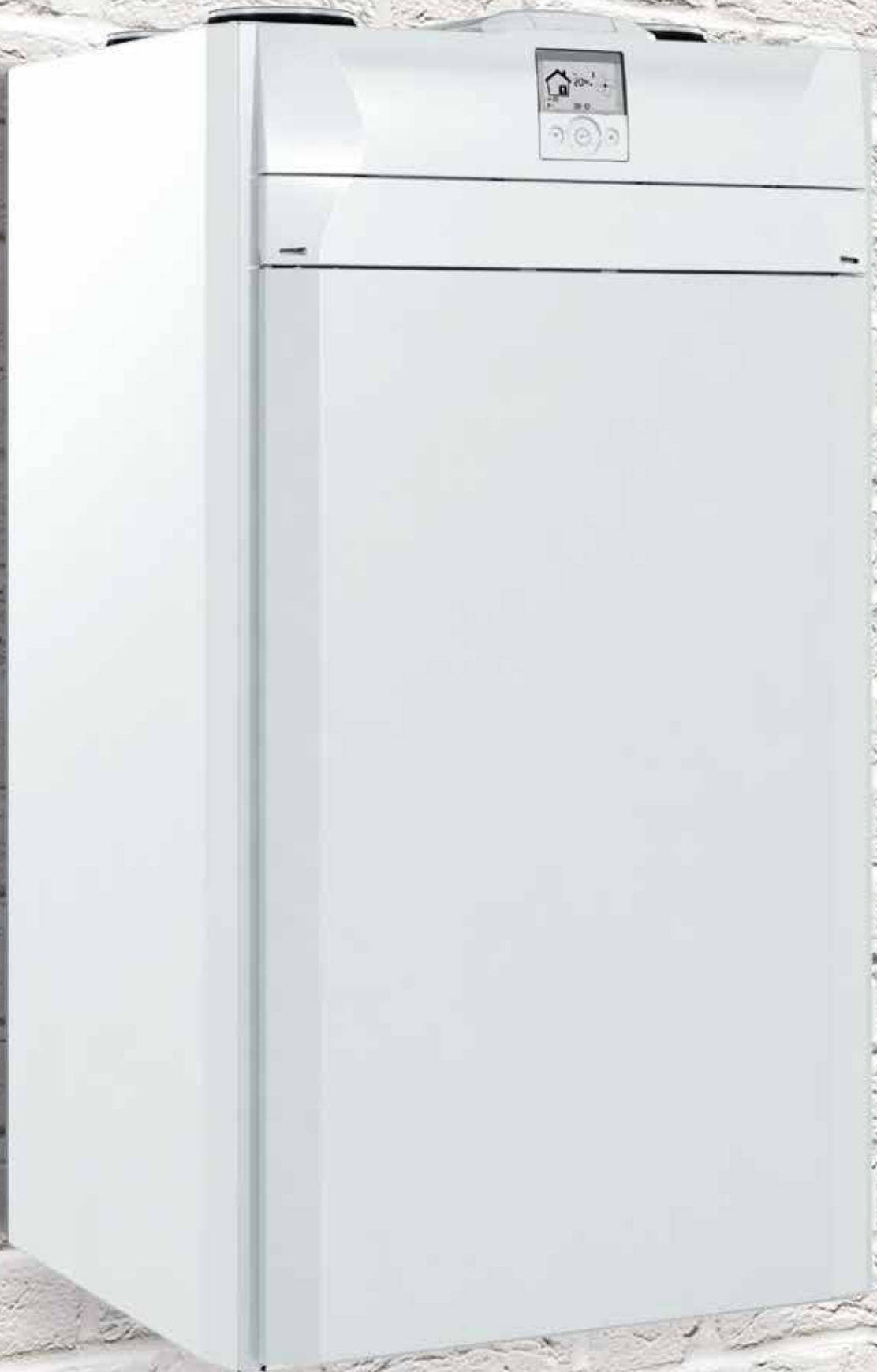

Pro ENY-SP version (ENY-SP-225 excluded) and Standard ENY-S version

1 ENY-SP version external structure

made of hot-dip galvanised steel sheet panels painted in RAL 9003 and satin finish obtained with epoxy paint dried in oven at 180 °C; the side panels are insulated with a 25 mm thick padding, while the inspection cover is completely removable and is insulated with a 30 mm thick padding.

ENY-S version external structure

made of hot-dip galvanised steel sheet panels painted in RAL 9003 and satin finish obtained with epoxy paint dried in oven at 180 °C; the inspection cover is completely removable and is insulated with a 30 mm thick padding.

2 EPDM fan / heat recovery access closure

3 EPDM filter access closure

4 Electric defrosting pre-heater

Hot filament resistance with reinforced metal lining, controlled by PWM signal (only versions with integrated resistance).

5 High efficiency filters compliant with Standard ISO 16890

The filters have the following features:

- class ePM₁ 55% - F7 for the supply air
- class ePM₁₀ 50% - M5 for the extracted air

6 ABS shanks for inlet/outlet flow connection

7/11 Extract air (7) and air supply (11) electric fan

consisting of:

- Permanent single-phase synchronous **EC motor** with protection against overtemperature of the motor and electronic components
- High efficiency **ABS fans** with backward-curved blades
- ABS **Motor/fan housing**.

8 High efficiency static recovery unit

with PET counterflow exchange plates.

The reachable efficiency obtainable may be higher than 90% because they ensure counterflow heat transfer between two air flows at different inlet temperatures.

The static recovery units do not feature moving parts and guarantee high reliability and safe operation. In order to increase the efficiency of the heat exchanger, the plate surfaces feature special swirlers.

9 By-pass damper

made entirely of ABS and motorised with a Valemo actuator.

10 Secondary by-pass damper

consisting of a steel blade and motorised with a Valemo actuator (Vertical version only).

12 T-EP control

Pro ENY-SP version (ENY-SP-225 excluded) and Standard ENY-S version

Vertical version

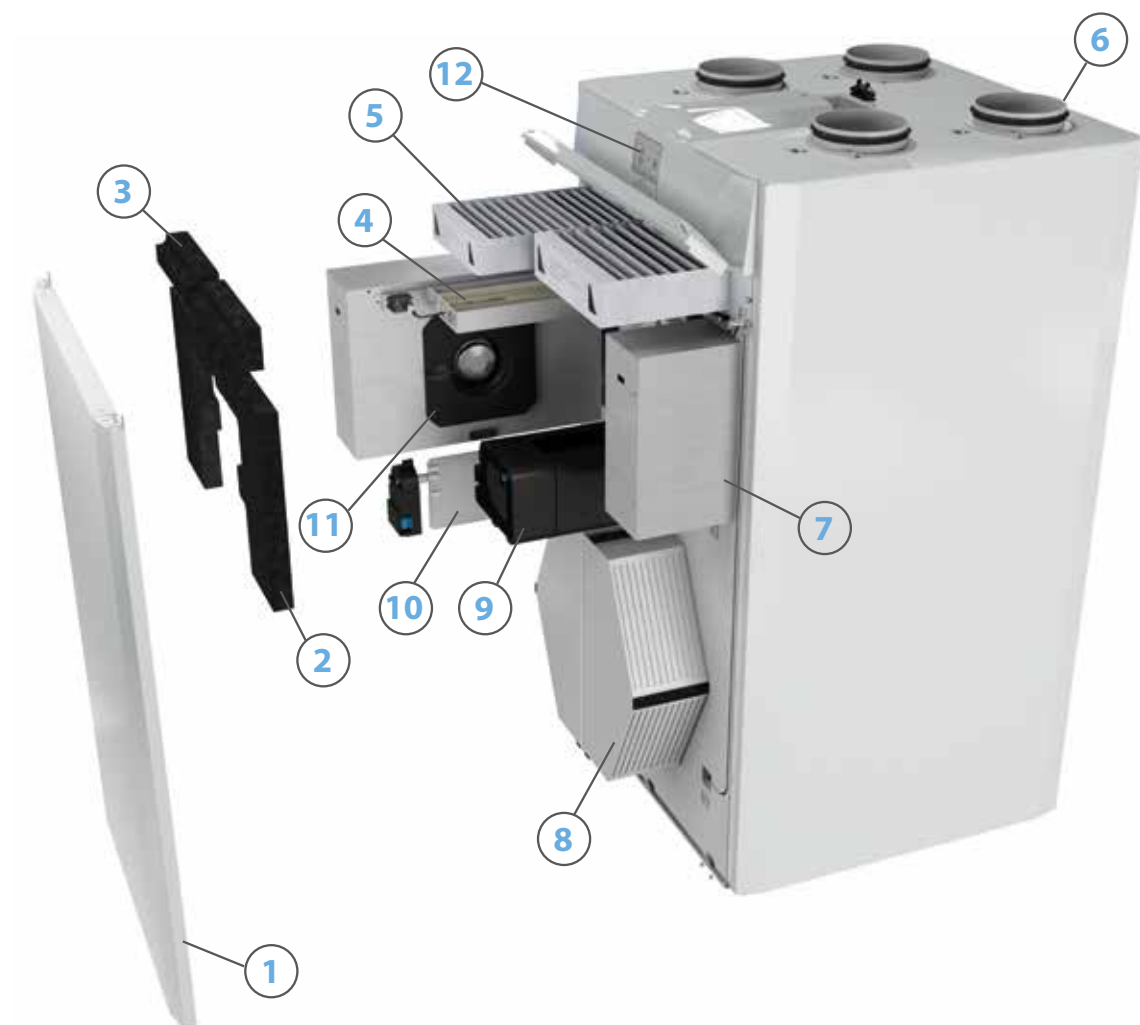

Energy Smart

Pro ENY-SP-225 version

1 ENY-SP version external structure

made of hot-dip galvanised steel sheet panels painted in RAL 9003 and satin finish obtained with epoxy paint dried in oven at 180 °C; the side panels are insulated with a 25 mm thick padding, while the inspection cover is completely removable and is insulated with a 30 mm thick padding.

2 Filter access closure

3 Electric defrosting pre-heater

Hot filament resistance with reinforced metal lining, controlled by PWM signal (only versions with integrated resistance).

4 High efficiency filters compliant with Standard ISO 16890

The filters have the following features:

- class ePM₁ 55% - F7 for the supply air
- class ePM₁₀ 50% - M5 for the extracted air

5 ABS shanks for inlet/outlet flow connection

6/9 Extract air (6) and air supply (9) electric fan

consisting of:

- Permanent single-phase synchronous **EC motor** with protection against overtemperature of the motor and electronic components
- High efficiency **ABS fans** with backward-curved blades
- **ABS Motor/fan housing.**

7 High efficiency static recovery unit

with PET counterflow exchange plates.

The reachable efficiency obtainable may be higher than 90% because they ensure counterflow heat transfer between two air flows at different inlet temperatures.

The static recovery units do not feature moving parts and guarantee high reliability and safe operation.

In order to increase the efficiency of the heat exchanger, the plate surfaces feature special swirlers.

8 By-pass damper

made entirely of ABS and motorised with a Valemo actuator.

T-EP control (included)

ENY-SP-225 Pro version

Vertical version

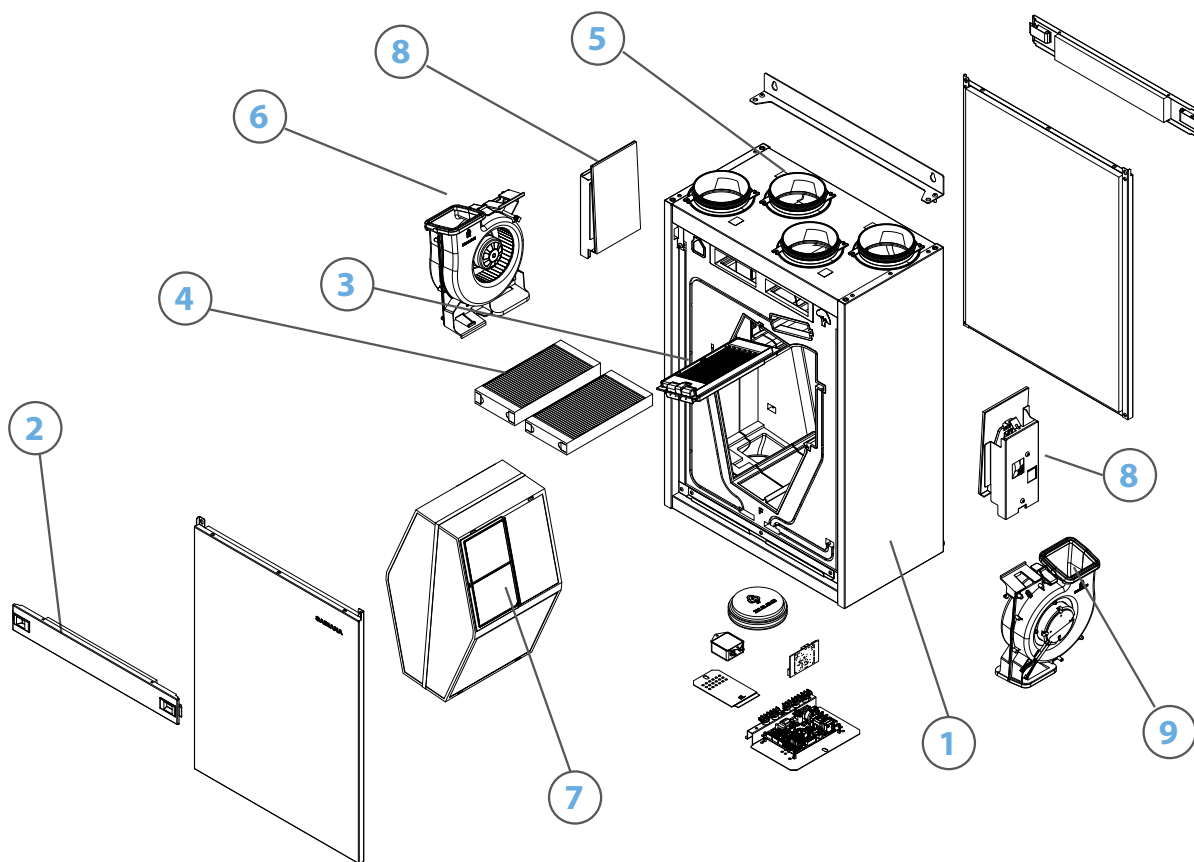

Energy Smart

Pro ENY-SP version (ENY-SP-225 excluded) and Standard ENY-S version

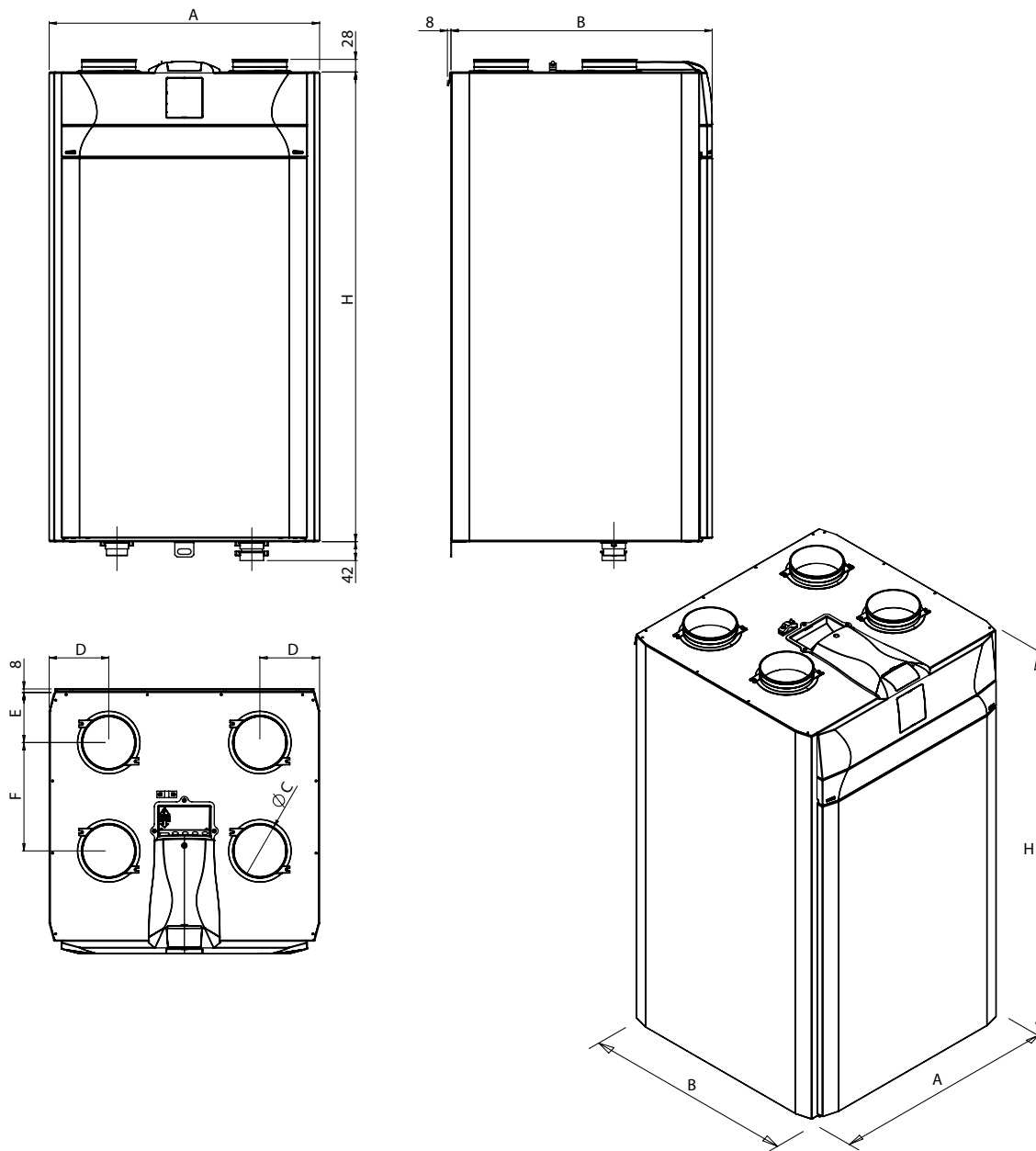

Model	Dimensions (mm)							Weight (kg)	
	A	B	ØC	H	D	E	F	With packaging	Without packaging
ENY-SP-180	600	580	125	1041	132	111	240	63	47
ENY-SP-280	600	630	160	1041	132	111	290	67	51
ENY-SP-370	660	680	160	980	147	126	305	75	56
ENY-SP-460	660	680	180	980	147	126	305	75	59
ENY-SP-600	660	680	180	980	147	126	305	75	60
ENY-S-170	547	505	125	1041	106	93,5	212,5	56	40
ENY-S-270	547	580	160	1041	106	111	240	64	48
ENY-S-360	547	630	160	1041	106	111	290	66	50
ENY-S-460	660	680	180	980	147	126	305	75	59
ENY-S-600	660	680	180	980	147	126	305	75	60

Pro ENY-SP version (ENY-SP-225 excluded) and Standard ENY-S version

Left side configuration default

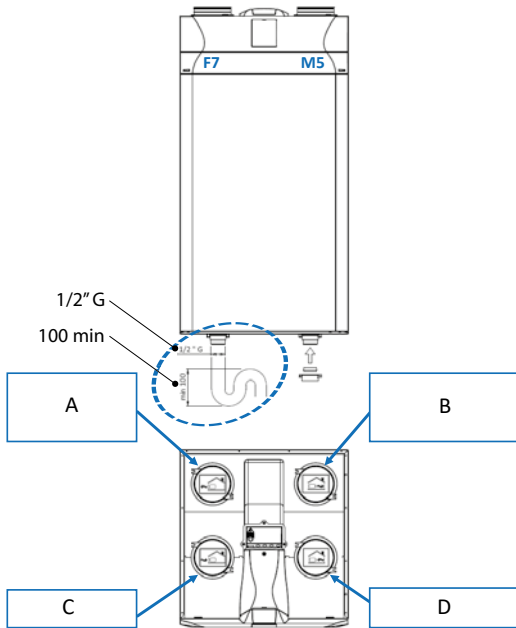

Right side configuration (optional)

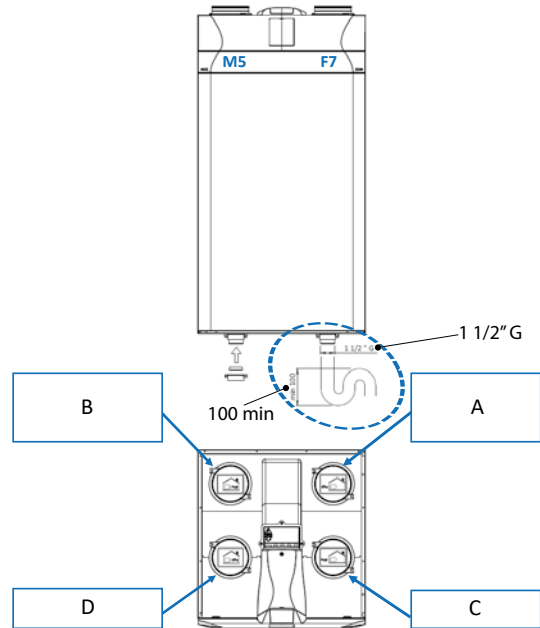

- A** = Extract air
- B** = Supply air
- C** = Fresh air
- D** = Extract air

Installation



Wall installation



Floor installation

ENY-SP-225 Pro version

Left side configuration

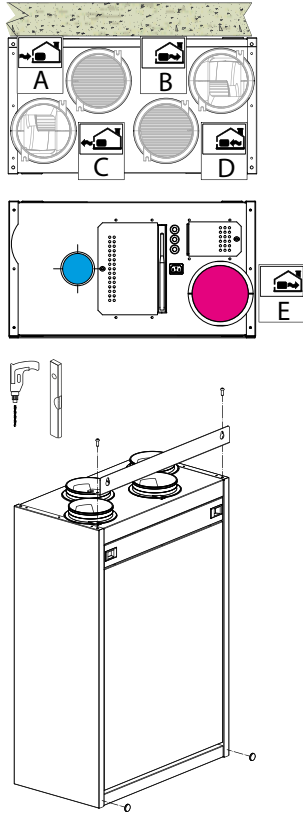

Right side configuration

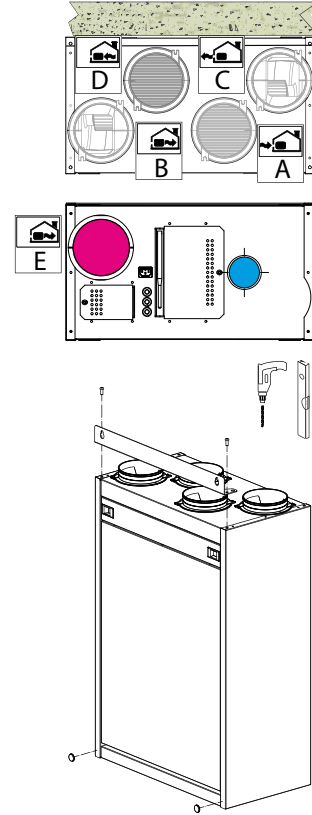

A = Fresh air

B = Supply air

C = Exhaust air

D = Extract air

E = Optional supply

Installation

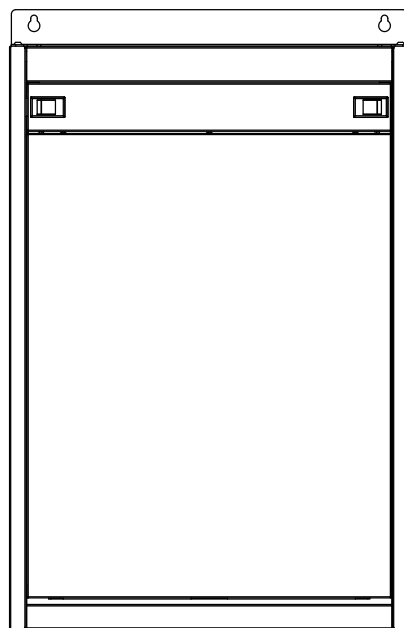

Wall installation

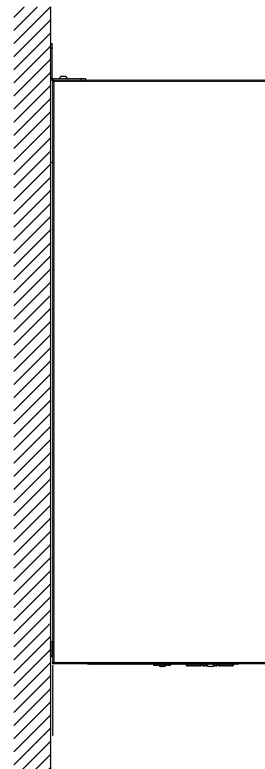

Pro ENY-SHP-150 version

- 1 ENY-SHP-150 version external structure**
made of hot-dip galvanised steel sheet panels.
- 2 Internal structure**
made of high density Polystyrene.
- 3 Frontal panel**
galvanized, insulated and painted in RAL 9003.
- 4 Main power board**
Main power board with built-in display, easy to use for calibration and activation of the unit.
- 5 High efficiency filters compliant with standard ISO 16890**
High efficiency micro-pleated filters, frontal extraction have the following features:
 - ePM₁ 55% - F7 class for the supply air;
 - ePM₁₀ 50% - M5 class for the extract air.
- 6 ABS shanks for inlet/outlet flow connection**
- 7 Caps made of ABS for the interchangeability of the position of the air distribution inlet/outlet connections**
- 8 Extract air and air supply electric fan**
high efficiency centrifugal fan with EC brushless motor and forward curved blades, steady control of air flow rate.
- 9 Static recovery unit**
Counterflow heat recovery unit with low pressure drops. It prevents any winter heat drops due to the introduction of fresh air, thereby recovering up to 88% of the extract heat.
The static heat recovery units do not feature moving parts and guarantee high reliability and safe operation.
- 10 Condensate collection tray**
The condensate collection tray made of ABS is designed for the correct condensate drain in every type of installations, ceiling or wall ones.
- 11 Condensate drain pipe**
The units are equipped with a flexible corrugated pipe 800 mm long, pre-assembled with 90° bend fastening. In case of water leakage, the drops are conveyed into the collection tray and directed towards the drain pipe.

Pro ENY-SHP-150 version

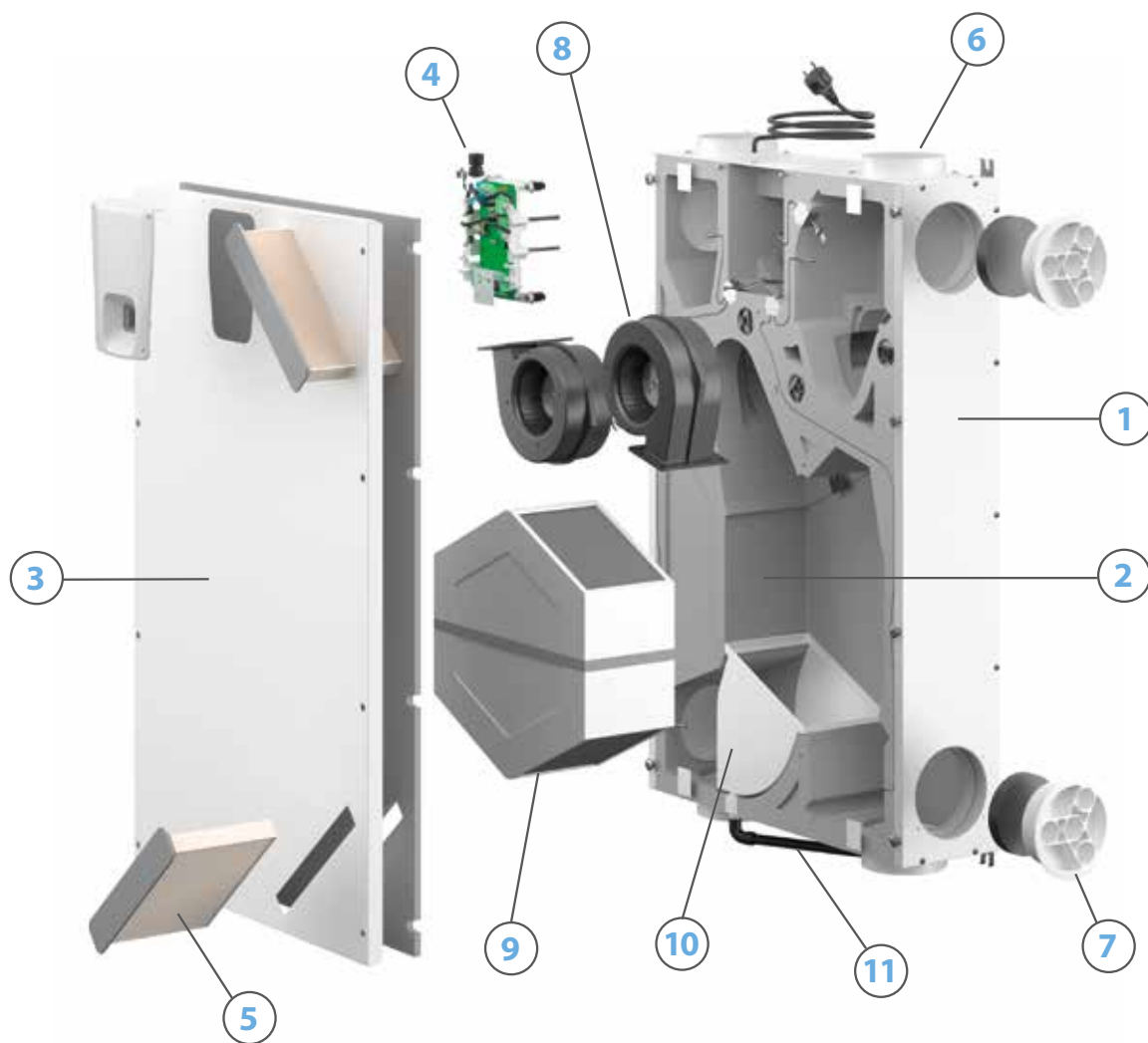

Energy Smart

Pro ENY-SHP-170 version

1 Pro ENY-SHP-170 version external structure

made of hot-dip galvanised steel sheet panels painted in RAL 9003 and satin finish obtained with epoxy paint dried in oven at 180 °C.

2 EPDM fan access closure

3 Polyethylene EPE filter access closure

4 Electric defrosting pre-heater

Electric heater hot filament with reinforced metal lining, controlled by PWM signal (only versions with integrated electric heater).

5 High efficiency filters compliant with standard ISO 16890

The filters have the following features:

- ePM₁ 55% - F7 class for the supply air;
- ePM₁₀ 50% - M5 class for the extract air.

6 ABS shanks for inlet/outlet flow connection

7/11 Extract air (7) and air supply (11) electric fan

consisting of:

- Permanent single-phase **synchronous EC motor** with protection against overtemperature of the motor and electronic components.
- **High efficiency PA fans** with backward-curved blades
- **Motor/fan housing.**

8 High efficiency static heat recovery unit

with PET counterflow exchange plates. The reachable efficiency obtainable may be higher than 90% because they ensure counterflow heat transfer between two air flows at different inlet temperatures. The static heat recovery units do not feature moving parts and guarantee high reliability and safe operation.

In order to increase the efficiency of the heat exchanger, the plate surfaces feature special swirlers.

9 By-pass damper with 2 louvers driven by the same motor

10 Main power board

Pro ENY-SHP-170 version

Horizontal and vertical version

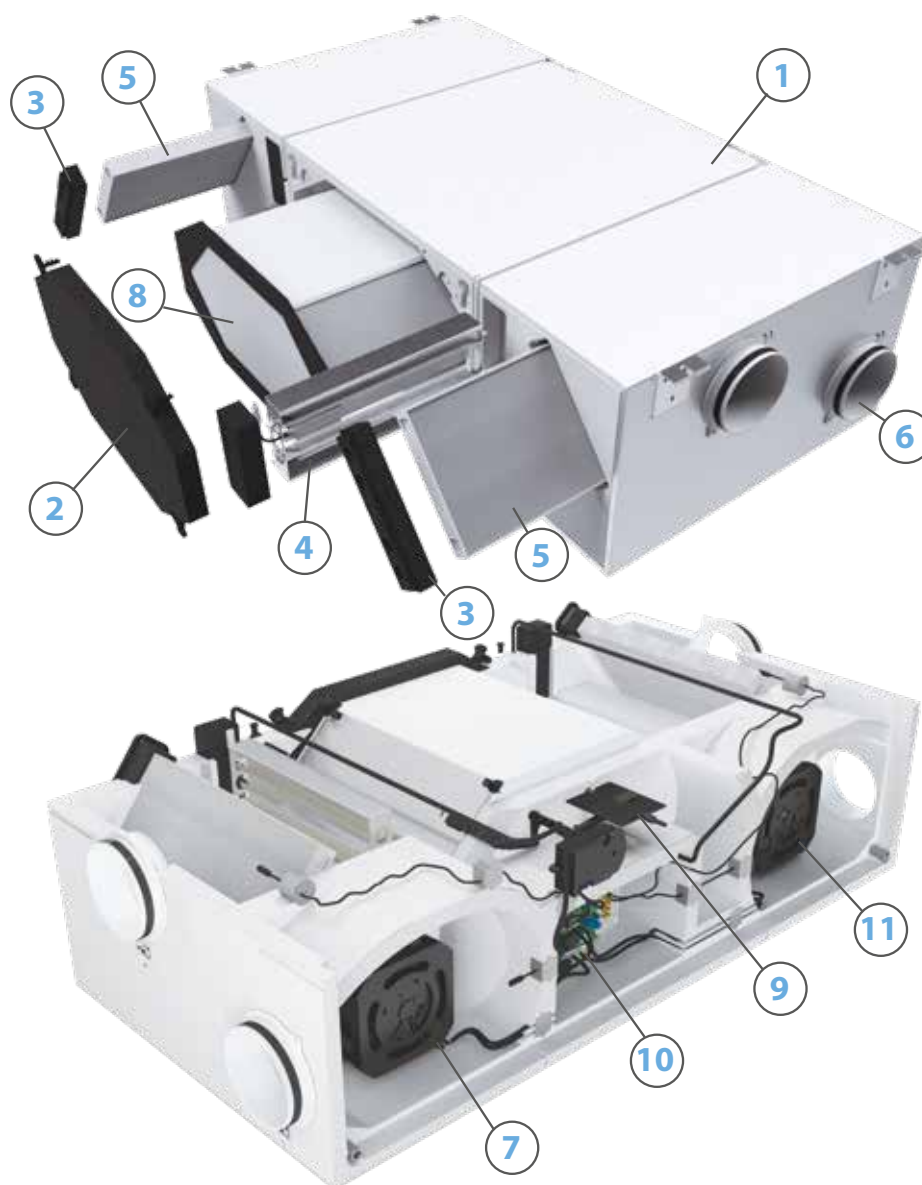

Energy Smart

Pro ENY-SHP-270 version

- 1 Pro ENY-SHP-270 version external structure**
made of hot-dip galvanised steel sheet panels
- 2 Internal structure**
made of high density Polystyrene
- 3 Frontal panel**
galvanized, insulated and painted in RAL 9003
- 4 Electric defrosting pre-heater**
Electric heater hot filament with reinforced metal lining, controlled by PWM signal (only versions with integrated electric heater)
- 5 High efficiency filters compliant with standard ISO 16890**
The filters have the following features:
 - ePM₁ 55% - F7 class for the supply air;
 - ePM₁₀ 50% - M5 class for the extract air
- 6 ABS shanks for inlet/outlet flow connection**
- 7 Extract air and air supply electric fan**
high efficiency centrifugal fan with EC brushless motor and forward curved blades, steady control of air flow rate
- 8 Static recovery unit**
Counterflow heat recovery unit with low pressure drops. It prevents any winter heat drops due to the introduction of fresh air, thereby recovering up to 88% of the extract heat.
The static heat recovery units do not feature moving parts and guarantee high reliability and safe operation
- 9 By-pass damper with 2 fins activated by stepper motor**
- 10 Condensate collection tray**
The condensate collection tray made of ABS is designed for the correct condensate drain in every type of installations, ceiling or wall ones
- 11 Main power board**

Pro ENY-SHP-270 version

Horizontal and vertical version

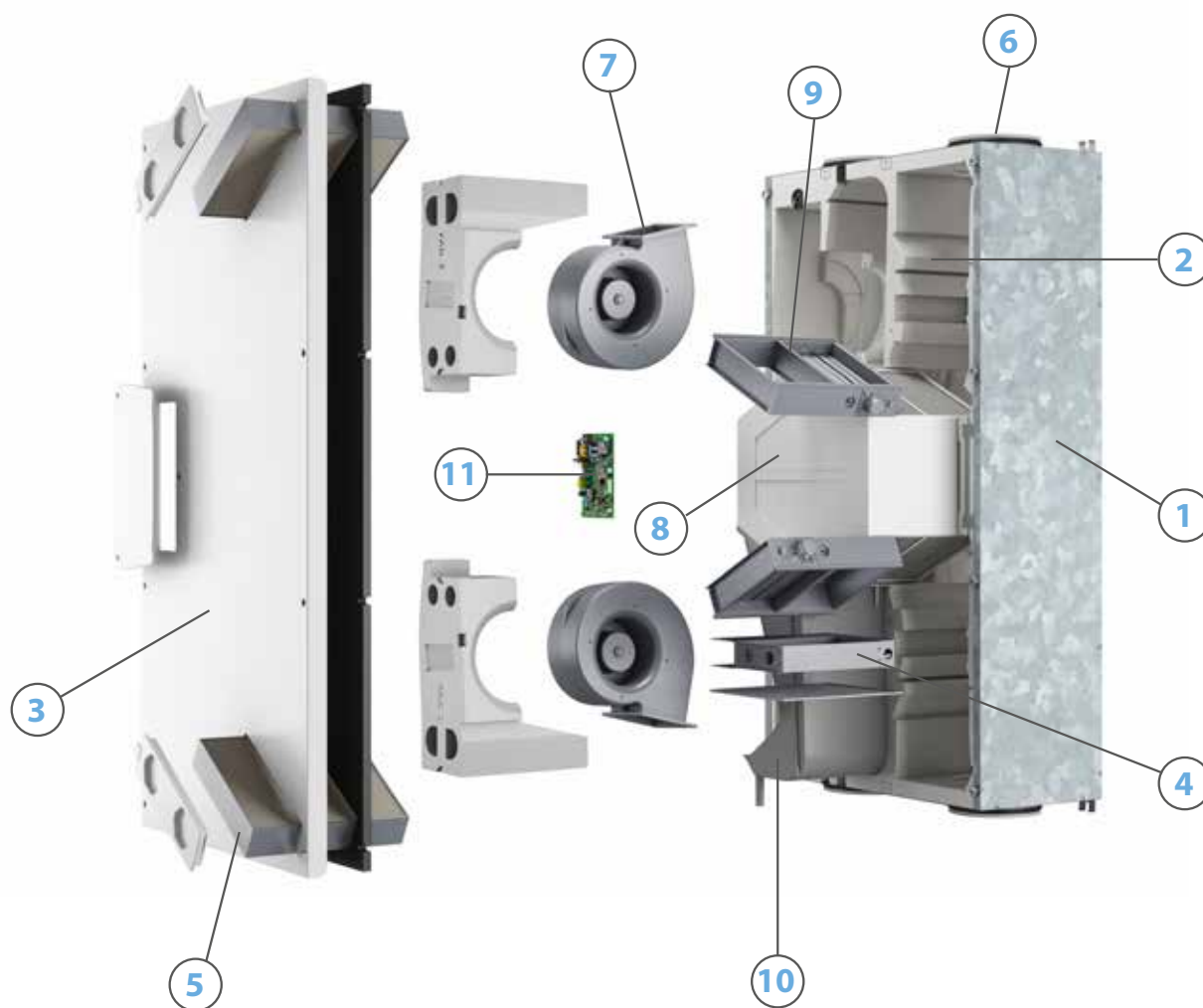

Energy Smart

Pro ENY-SHP-150 version

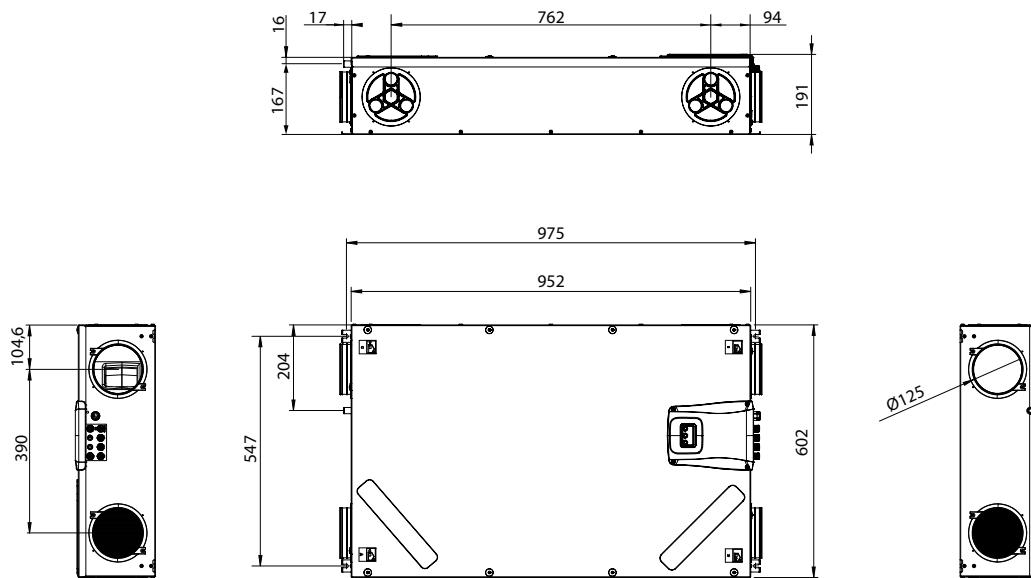

	Weight with packaging	Weight without packaging
ENY-SHP-150	25 kg	23 kg

Installation

The ENY-SHP-150 unit can easily be installed both horizontally and vertically. Special support brackets pre-fitted on the unit are provided to install the unit horizontally on the ceiling and to install the unit vertically (especially in gaps between plasterboard walls and load-bearing walls).

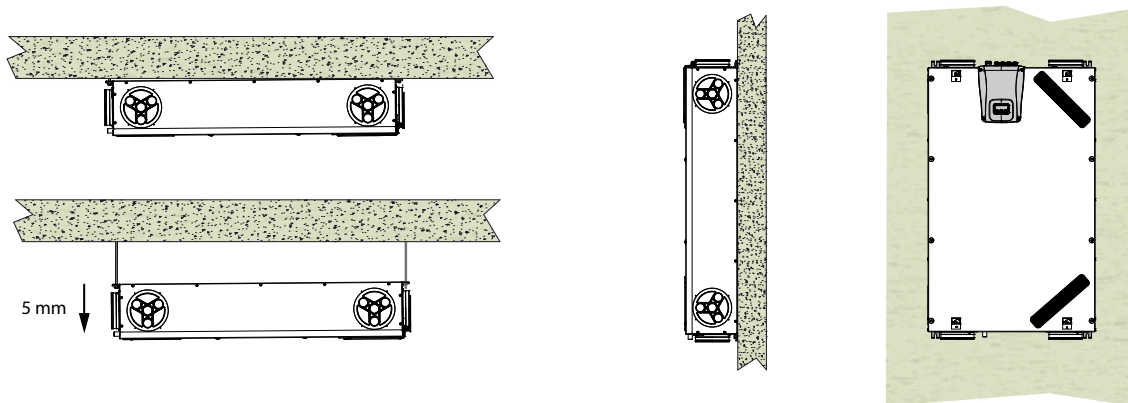

Horizontal installation

Spacer bars can be used to adjust the distance from the ceiling. It is recommended to install the unit tilted towards the side where the ePM₁ 55% - F7 filter is placed, in order to facilitate condensate drainage. Provide a slope of min. 5 mm towards the condensate drain.

Vertical installation

Place the unit with the touch screen control upwards, so that the condensate drain connection remains downwards.

The instruction manual indicates the appropriate maintenance clearance for each type of installation.

Pro ENY-SHP-170 version

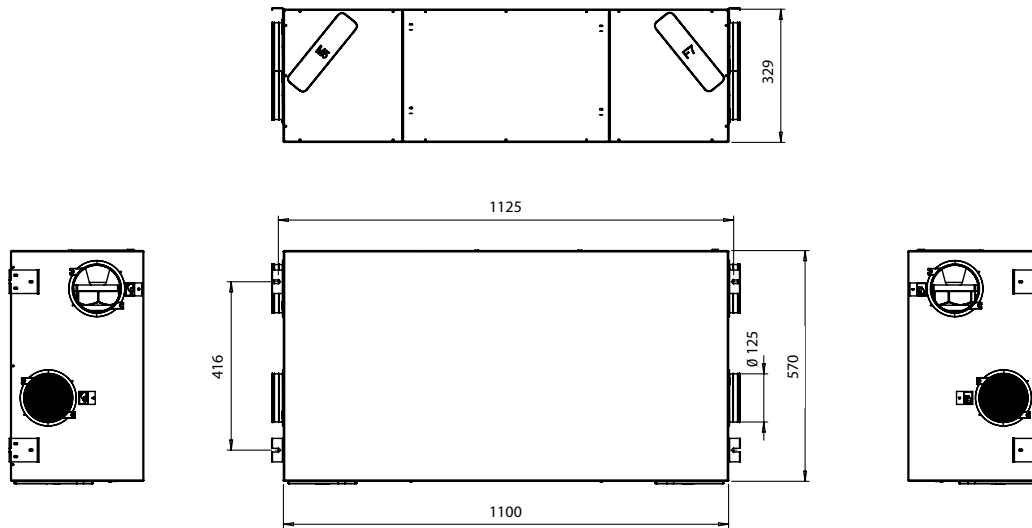

	Weight with packaging	Weight without packaging
ENY-SHP-170	35 kg	31 kg

Installation

The ENY-SHP-170 unit can easily be installed both horizontally and vertically. Special support brackets are provided to install the unit horizontally on the ceiling and to install the unit vertically (especially in gaps between plasterboard walls and load-bearing walls).

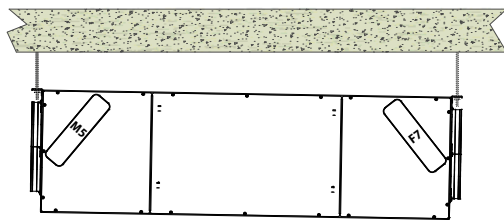

Horizontal installation

Spacer bars can be used to adjust the distance from the ceiling. It is recommended to install the unit tilted towards the side where the ePM₁ 55% - F7 filter and the condensate drain pipe are placed, in order to facilitate condensate drainage (provide a slope of 2% towards the filter and of 1% towards the condensate drain pipe).

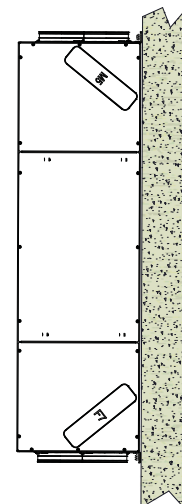

Vertical installation

Place the side ePM₁ 55% - F7 downwards the unit..

The instruction manual indicates the appropriate maintenance clearance for each type of installation.

Pro ENY-SHP-270 version

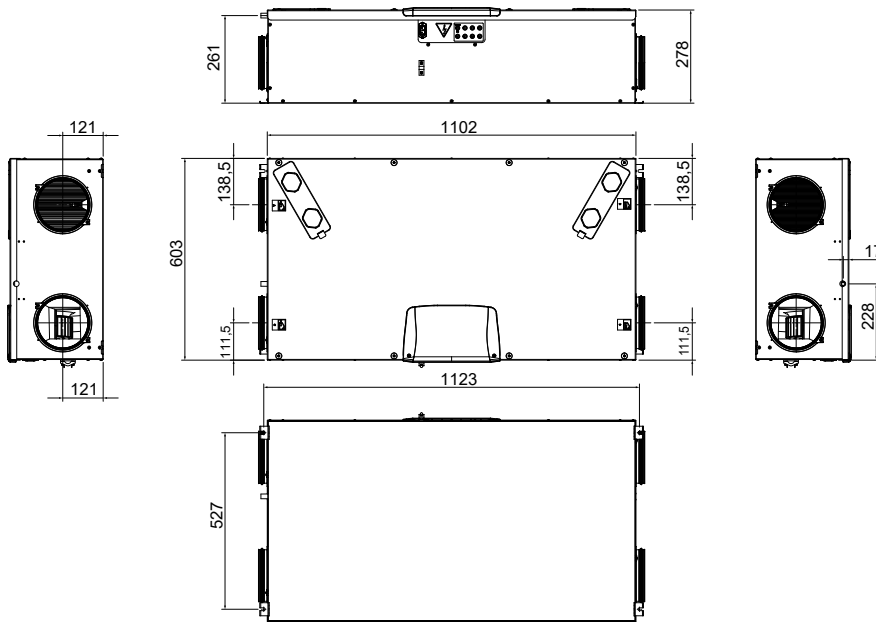

	Weight with packaging	Weight without packaging
ENY-SHP-270	38 kg	31 kg

Installation

The ENY-SHP-270 unit can easily be installed both horizontally and vertically. Special support brackets are provided to install the unit horizontally on the ceiling and to install the unit vertically (especially in gaps between plasterboard walls and load-bearing walls).

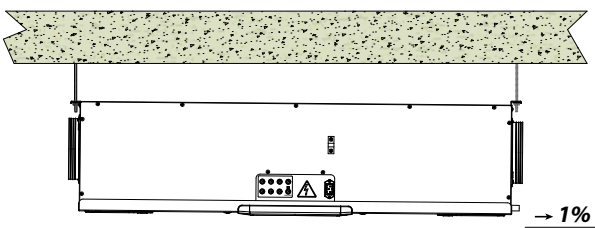

Horizontal installation

Spacer bars can be used to adjust the distance from the ceiling. It is recommended to install the unit tilted towards the side where the ePM1 55% - F7 filter and the condensate drain pipe are placed, in order to facilitate condensate drainage (provide a slope of 2% towards the filter and of 1% towards the condensate drain pipe).

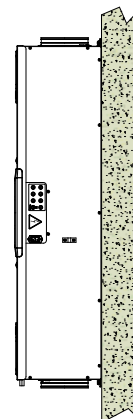

Vertical installation

Place the side ePM1 55% - F7 downwards the unit.

The instruction manual indicates the appropriate maintenance clearance for each type of installation.

Pro ENY-SHP-150 version

The standard configuration of the unit provides that the air distribution connections are fitted on the short sides of the unit, with the extract air fan fitted on the short side nearest to the control panel.

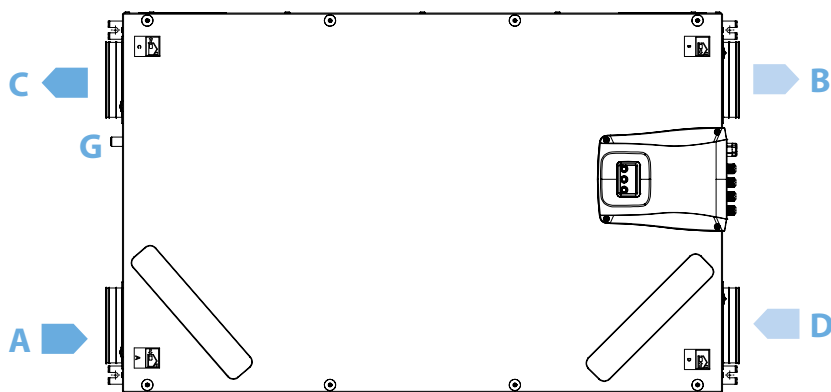

View from above

If necessary, it is possible to turn of 90° the position of one or more air connections to drive them on the long side near the unit.

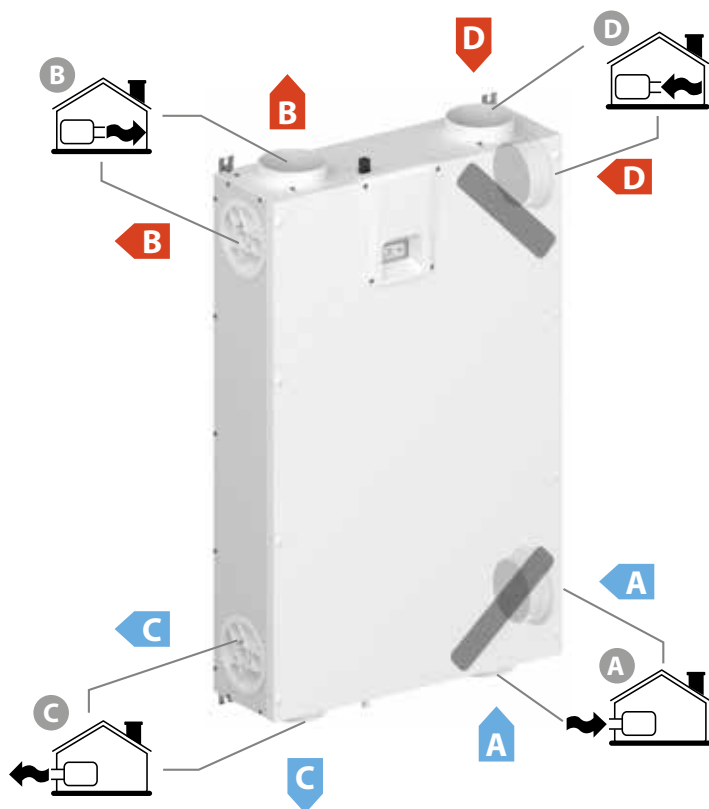

- A = Fresh air
- B = Supply air
- C = Exhaust air
- D = Extract air
- G = Condensate air

Pro ENY-SHP-170 version

Optional left side configuration
(view from above)

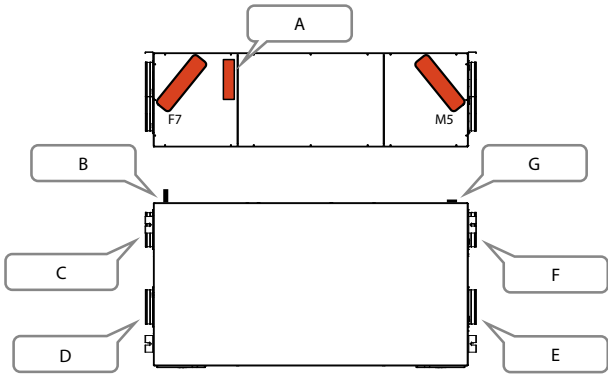

Default right side configuration
(view from above)

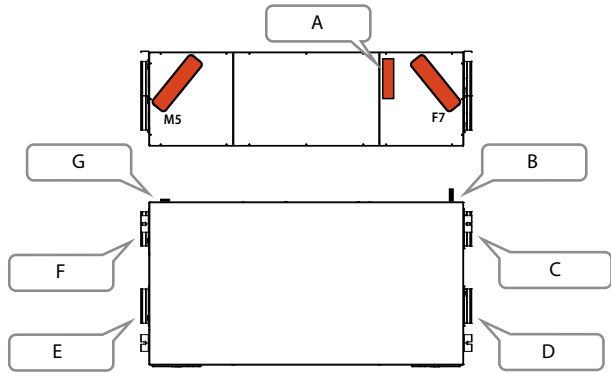

A = Electric pre-heater
B = Condensate drainage

C = Exhaust air
D = Fresh air

E = Extract air
F = Supply air

G = Cap

Standard initial configuration

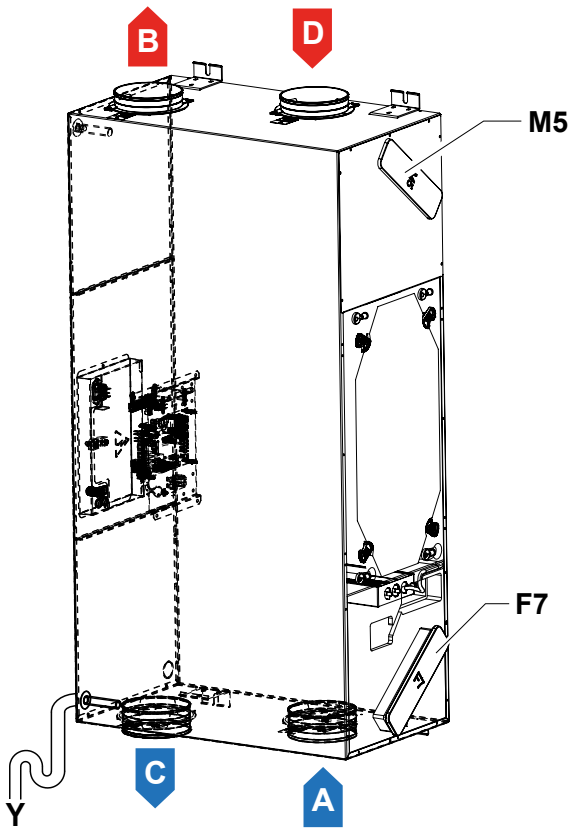

A = Fresh air

B = Supply air

Final inverted configuration

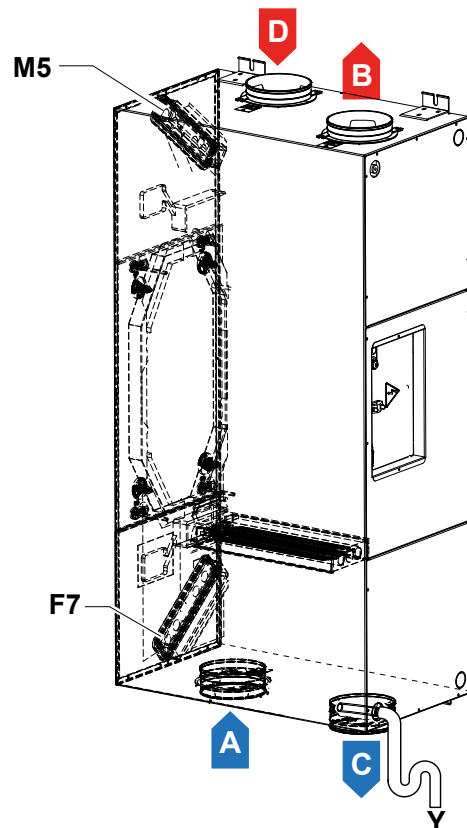

C = Exhaust air

D = Extract air

Pro ENY-SHP-270 version

Left horizontal side installation

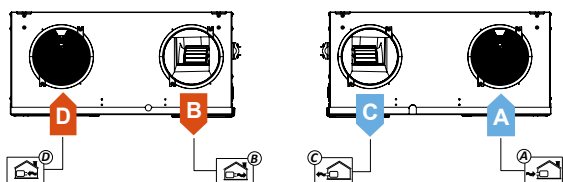
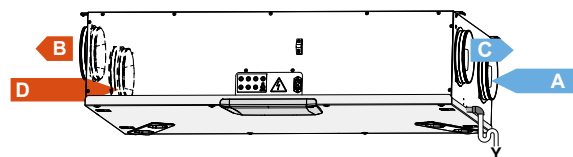

Right horizontal side installation

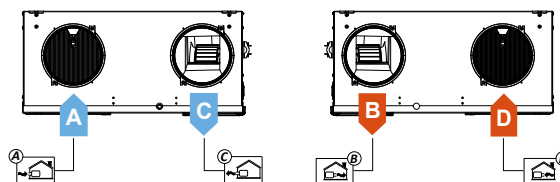
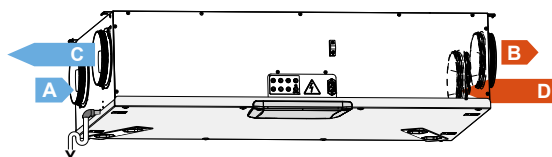

Left vertical side installation

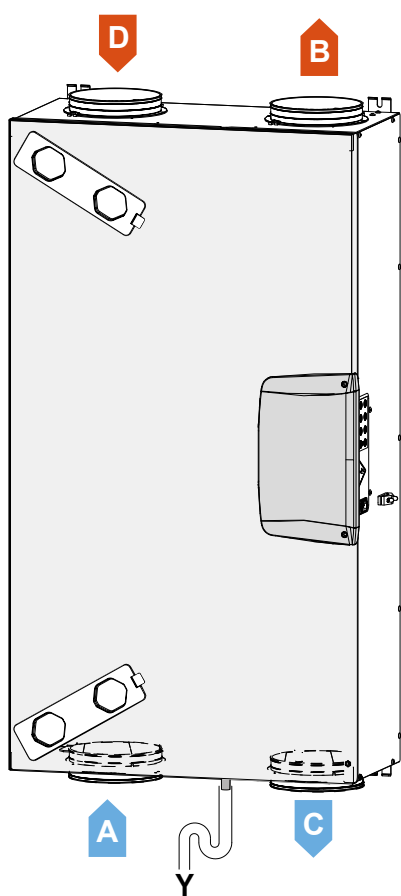

Right vertical side installation

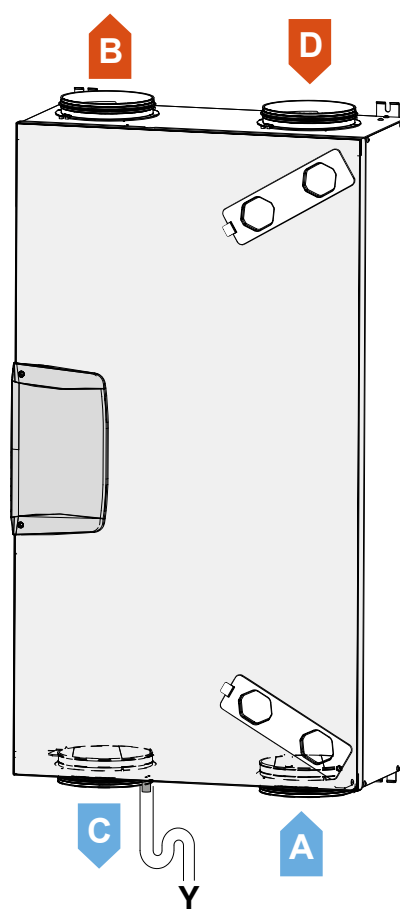

A = Fresh air

B = Supply air

C = Exhaust air

D = Extract air



T-EP control panel

The Energy Smart vertical units and the ENY-SHP-170 and ENY-SHP-270 sizes are equipped as standard with a T-EP control panel. For the size ENY-SHP-150 such an interface is an accessory instead.

The use of the interface is very intuitive and thanks to the icons on the screen, the two keys and the touchpad, it is possible to display and change the operating status of the unit, display the values read by the temperature sensors and humidity sensor (if any), and display any alarm.

The use of the interface is simplified by the presence of two sub-menus:

- **User Settings Menu** where the user can select the operating mode and set the clock.
- **Technical Settings Menu** where the installer can calibrate the flow rates, change the unit operating parameters and monitor the operating status..

The **user settings menu** is used to select the following unit operating modes:

- **Manual Mode**

Customised selection of desired air flow rate in manual mode:

- 100% - Nominal ventilation (standard)
- 70% - Reduced ventilation (night-time)
- 45% - humidity control for high humidity rate environments
- 25% - humidity control for low humidity rate environments.

- **Party Mode**

Timed function, active for 3 hours after activation, in which the nominal speed is increased by 30%.

- **Holiday Mode**

Anti-mould function with the fans at minimum speed.

- **Automatic Mode**

Speed controlled by means of an automatic control cycle relating to ambient instantaneous humidity and CO₂ variations. This mode is only available for the Pro version or for units equipped with an air quality sensor (humidity or CO₂).

The user menu is also used to set the clock and perform weekly programming.

For the **Technical Settings Menu**, see the "Energy Smart" technical guide.

ENY-SHP-150 control panel

The Energy Smart ENY-SHP-150 unit is equipped with a built-in display of the control fitted on the unit.

The control is easy to use and lets the reset of filter change timer and having access to the technical menu of the following functions:

- To do the automatic fan calibration during the installation.
- To set the filter change time during the installation.
- To set the automatic operating mode with the use of the built-in humidity probe.
- To activate the external modulating electric heater or relay for the ON/OFF valves with the antifreeze pre-heating function.
- To set the dry contact terminals and the digital signal during the installation.
- To visualize the operating parameters.
- To visualize the alarm and filter change notifications.

To activate further ventilation modes with the use of the T-EP Accessory.



When installing in regions with particularly harsh climatic conditions, the units must be equipped with a preheating coil to prevent freezing phenomena on the discharge air outlet side. The electric heater can be installed on the fresh air intake section, see the next dedicated paragraph, or, only for the units from size 170 to size 600, the version with electric heater fitted on the unit (E version) is available. In this case the electric heater is fitted within the ventilation unit, near the fresh air inlet section. The fresh air temperature drops below the default limit, resulting in the risk of the counterflow heat exchanger freezing, the electric resistance is switched on and the thermal power is adjusted continuously in order to maintain the discharge air temperature within the desired range.

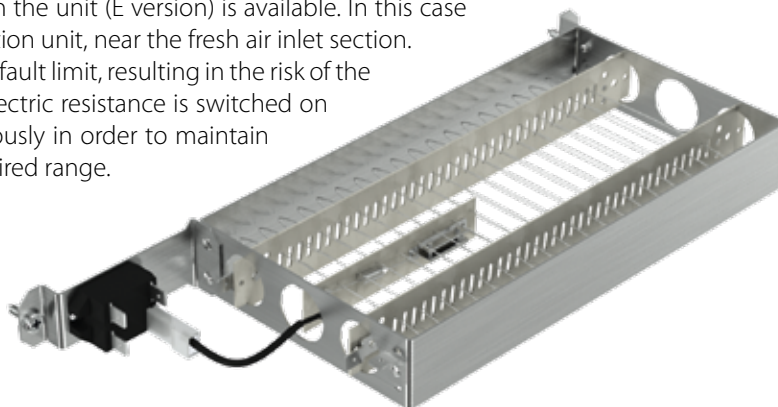

Accessories

ES-E External pre-heating circular electric heater



ES-P Feet

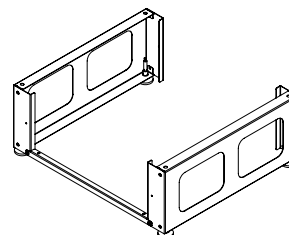

ES-DP Pressure sensor



ES-SU Capacity humidity sensor

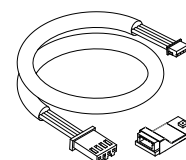

KNX-RVU KNX interface kit



Sabiana S.p.A. offers a wide range of accessories **designed for air distribution** in controlled mechanical heat recovery ventilation systems, used to ventilate small residential and commercial buildings, to install an air distribution network in the various environments and meet any need.

The system consists of several components:

- **Double wall**, circular and semicircular **flexible duct** made of high density polyethylene (PE), smooth on the inside, suitable for false ceiling, wall and underfloor installation. On the internal surface, the ducts have an antibacterial and antistatic layer to ensure constant air cleaning. The flexible ducts are also available without the antibacterial and antistatic layer.
- Moulded **PE accessories**, including 90° horizontal and vertical bends, connectors, bracket elements, grid adapters and inlet and outlet valves complete the range of products.

The **Sabiana Energy Smart** unit is connected to the universal distribution boxes through insulated ducts and silencers, while the flexible duct is used to supply fresh air in the premises and to extract the stale and damp air from bathrooms and kitchens. To complete the system, there is a range of accessories, connectors, fasteners, and bends, which ensure sealed connections without using adhesive tape or glue, to fasten the flexible duct to the floor or ceiling, to make 90° horizontal or vertical bends with radius of curvature below that of the duct.

The volume of air going through each duct is determined by the flow rate regulators installed on the outlets of the universal distribution boxes.

On request, Sabiana provides a free configurator for defining the number of rings to be removed from the flow rate regulators.

The Sabiana configurator requires the following information:

- 1 Air flow rate of each circuit;
- 2 Type of flexible duct;
- 3 Length of duct paths;
- 4 Number and type of bends (horizontal or vertical).

For all the conducts, diffusers and related accessories see the “Energy Smart” technical guide.



Energy Smart

Follow us on

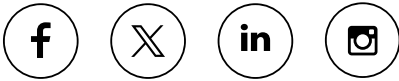

Sabiana app

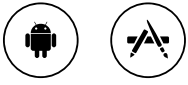

01/2025



SABIANA SpA

Società a socio unico

Via Piave 53 - 20011 Corbetta (MI) Italia

T. +39 02 97203 1 r.a. - F. +39 02 9777282

info@sabiana.it

www.sabiana.it

Management and Direction ARBONIA AG



Sabiana 2 and Sabiana 3 - Operative unit "via Virgilio 2 - Magenta (MI)"
Sabiana 4 - Operative unit "via Zanella 27 - Corbetta (MI)"